

# Jonard MS-326 - Mid Span Slit & Ring Tool (5mm-10mm)

Product Images

Product Code: E00-7630

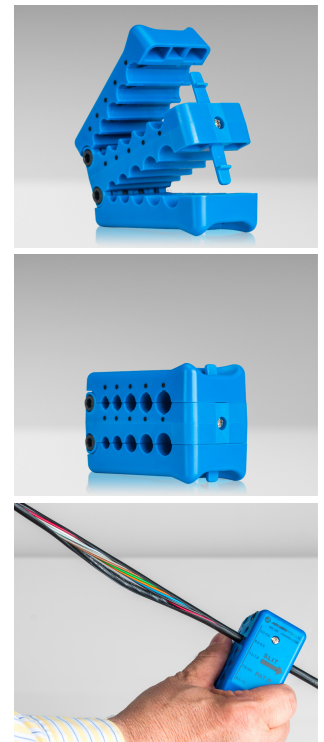

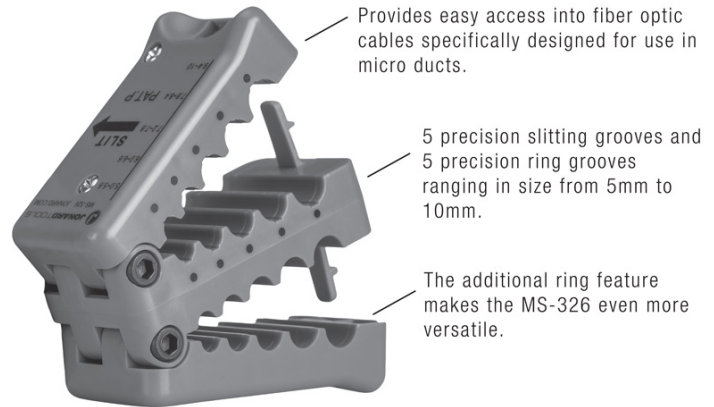

## Short Description

---

The patented MS-326 micro duct fibre cable slit and ring tool is designed to provide easy access into fibre optic cables specifically designed for use in micro ducts. These cables have a thin wall jacket design that is difficult to open without causing damage to the buffer tubes inside, but the MS-326 addresses that concern. The MS-326 will also slit open thin wall buffer tubes.

Building on the popularity of Jonard Tools' MS-6 and MS-26 fiber optic mid span slitting tools we've incorporated a ring feature into the MS-326 making it even more versatile.

The MS-326 consists of 5 precision slitting grooves and 5 ring grooves ranging in size from 5mm to 10mm.

Groove Sizes: 5.0 - 5.6mm | 6.0 - 6.6mm | 7.2 - 7.8mm | 7.8 - 8.4mm | 9.4 - 10mm

Easy to use:

1. Open the appropriate side of the tool
2. Select the correct groove size
3. Place the cable in the tool and close to lock in place
  - To ring: rotate the tool 3-6 times in direction of the arrow
  - To slit: use markings to align cable, pull in direction of arrow
4. Open the tool and remove the cable. If slit, peel the jacket along the slit lines

Cut Type: Slit, Ring

Cable Type: Loose Tube, Jacket

2 Features: 10 Precision Grooves

Weight: .25 lbs (0.11kgs)

Dimensions: 2.87" (73 mm) x 1.5" (38 mm) x 2.1" (53.5 mm)

UPC No.: 811490019263

## Description

---

The patented MS-326 micro duct fibre cable slit and ring tool is designed to provide easy access into fibre optic cables specifically designed for use in micro ducts. These cables have a thin wall jacket design that is difficult to open without causing damage to the buffer tubes inside, but the MS-326 addresses that concern. The MS-326 will also slit open thin wall buffer tubes.

Building on the popularity of Jonard Tools' MS-6 and MS-26 fiber optic mid span slitting tools we've incorporated a ring feature into the MS-326 making it even more versatile.

The MS-326 consists of 5 precision slitting grooves and 5 ring grooves ranging in size from 5mm to 10mm.

Groove Sizes: 5.0 - 5.6mm | 6.0 - 6.6mm | 7.2 - 7.8mm | 7.8 - 8.4mm | 9.4 - 10mm

Easy to use:

1. Open the appropriate side of the tool
2. Select the correct groove size
3. Place the cable in the tool and close to lock in place
  - To ring: rotate the tool 3-6 times in direction of the arrow
  - To slit: use markings to align cable, pull in direction of arrow
4. Open the tool and remove the cable. If slit, peel the jacket along the slit lines

Cut Type: Slit, Ring

Cable Type: Loose Tube, Jacket

Features: 10 Precision Grooves

Weight: .25 lbs (0.11kgs)

Dimensions: 2.87" (73 mm) x 1.5" (38 mm) x 2.1" (53.5 mm)

UPC No.: 811490019263